



## Basic Information

PureAir's Chemisorbant Media captures and removes problematic gases, vapors, and odors from the environment. PureAir's variety of media provide the most cost-effective and optimal solutions for each unique application.

### Defining the Problem

Identify which gas is causing the problem to determine the best solution.

Below are the main gases PureAir's Chemisorbant Media target:

- Ammonia
- Hydrogen sulfide
- Sulfur dioxide
- Nitric oxide
- Formaldehyde
- Chlorine

Note: Unsure of which gas is causing the problem? PureAir can help identify the problematic gases through experience and various tools, one of which is the Corrosivity Test Kit that identifies airborne corrosive gases.

### Media Types

Interested in a specific media? Ask the factory to send a specification sheet, which includes removal capabilities.

#### Activated Alumina Base:

- PureAir 4
- PureAir 8
- PureAir 12
- Alumina
- Safetysorb
- Siloxsorb

#### Clay and Mineral Base:

- PureAir Z
- PureAir 6Z
- Sulphasorb Fe™

#### Engineered Carbon Base:

- AC-C
- AC-X
- Ammoniasorb®
- NOXsorb
- Sulphasorb XL™
- Sulphasorb FeXL
- Sulphasorb 2™

#### Blended Media:

- PureAir CP Blend
- PureAir CPS Blend
- PureAir CPS12 Blend
- PureAir CPZ Blend
- PureAir PP Blend
- PureAir TriBlend
- PureAir VOCsorb Blend

### Media Filter Housings

Incorporate any media into these various housings and filters:

- Loose Media by the Box or Supersack
- PurePak (PP12/PP18) Modules
- Honeycomb Filters
- Pleated Media Filters
- Canisters

\*Ask the factory for more details on each of these options.



Made in the U.S.A.

# REPLACEMENT MEDIA

## Basic Information

Keeping a system serviced with high-performance chemisorbant media is important. If the media is not changed out when it is due for replacement, the system cannot function properly and unwanted gases will be released into the environment. The life span of media will vary depending on many factors, but it will usually last for a little more than one year. Maintain system performance with PureAir's superior quality media, as demonstrated by third party testing.



## WHEN SHOULD MEDIA BE REPLACED?

There are a few ways to check a PureAir system and media.

The **Manual Bed Indicator** performs as a dip stick in the unit. When the metal indicator is pulled out, there will be discoloration on it showing corrosion levels. When the discoloration reaches the halfway point, it is time to consider changing the media.

The **Electronic Bed Monitor (EBMv2)** alerts users before it is time for media changeout.

## SAMPLING MEDIA FOR LAB TESTING

Complimentary media testing is offered to all PureAir customers. The testing requires collecting a two-cup sample of media from each port of the system. As soon as the media is received, it is tested, and a report is created and returned with the remaining media life analysis.

## TESTING AIR QUALITY

A Corrosivity Test Kit can also be used, specifically for commercial and industrial applications, to test the quality of the air in the room and ensure the system is performing as intended.

The **Environment Corrosivity Monitor (ECMv2)** allows users to complete the corrosivity test electronically, through real-time monitoring.

## MEDIA SUBSCRIPTION PLAN

Interested in a customizable dedicated service package that includes automatic reorder of media at a discounted price? Ask the factory about PureAir's new media subscription plan.

**Tier 1:** Dedicated Virtual Assistance from a Sales Support Associate

**Tier 2:** On-site Consultation and Sales Support

**Tier 3:** On-site Consultation and Sales Support plus Electronic Monitoring

	Tier 1	Tier 2	Tier 3
Discount on future media orders	X	X	X
Free quarterly media testing; bags and labels will be sent each quarter	X	X	X
Sales support associate will send a reminder to check media bed indicator on a quarterly basis with instructions	X	X	X
Discount on future media orders and changeout service		X	X
A representative will come on site to check the media bed indicator and take samples on a quarterly basis. Mist and grease filter will be cleaned if needed		X	X
EBMv2 reports will be provided			X
Other air quality monitoring will be provided as needed			X

+1 678.935.1431 | Toll Free: 866.543.7479

www.PureAirFiltration.com | 6050 Peachtree Pkwy, Suite 240-187, Atlanta, GA, 30092 USA

# Drum Scrubber (DS)

PureAIR

FILTRATION

## Economical, Durable Deep Bed Design

### SPECIFICATIONS:

Applications	Wastewater odor removal
Airflow Range	0 CMH (0 CFM) – 2,123.7 CMH (1,250 CFM) <i>*Please review the model selection table for more information</i>
Configuration	Vertical airflow
Construction Material	<b>Standard:</b> High-density polyethylene (HDPE) <b>Other options:</b> Stainless Steel, Fiberglass reinforced plastic
Particulate Filtration	<b>Odor Control Applications:</b> Mist and Grease Filter <b>Other Applications:</b> 5 cm (2 in), 30% MERV 8 Prefilter, 15 cm (6 in), 95% MERV 13 Final Filter <i>*Other filter sizes/options available upon request.</i>
Blower Configuration	<b>DRAWTHRU:</b> Standard and allows the blower to work in clean air, thus making it last longer and require less maintenance <i>*Redundant blowers and other special options available</i>
Customizable	Multiple sizes and configurations available, reference model selection table for details. Add-on accessories like sound enclosures are available. Contact factory for more information. <i>PureAir specializes in customization.</i>



### BENEFITS:

- Low maintenance: Ease of replacing and disposing of spent media
- Multiple beds available for adsorbent media. For more information on the adsorbent media, please see the media brochure

### MEDIA BED INDICATOR:



This unit is equipped with a metal media bed indicator. The device is positioned inside the system at an angle against the direction of airflow to detect the media expiration level.

- Dark, corroded coloration on indicator shows where media has expired. Once half the device has been corroded, contact the factory to replace the media and ensure the continued proper functioning of the system.
- Interested in instant notification of media life? Ask about the electronic media bed monitor (EBMv2) that can be added as a system upgrade.

+1 678.935.1431 | Toll Free: 866.543.7479

www.PureAirFiltration.com | 6050 Peachtree Pkwy, Suite 240-187, Atlanta, GA, 30092 USA



## MODEL SELECTION TABLE

DS MODEL #	AIR FLOW RANGE CMH (CFM)	MOTOR RANGE kW (HP)	MEDIA VOLUME M <sup>3</sup> (FT <sup>3</sup> )*	Shipping Weight KG (LBS)	Operating Weight KG (LBS)
100	85 - 170 (50 - 100)	.37 (.5)	.14 (5)	79 (175)	156 (345)
300	170 - 510 (100 - 300)	.56 (.75)	.25 (10)	120 (270)	350 (770)
500	510 - 850 (300 - 500)	1.1 (1.5)	.42 (17)	200 (440)	485 (1070)
1000	850 - 1700 (500 - 1000)	2.2 (3)	1.1 (39)	272 (600)	921 (2030)

\* Special Airflows are Available

## Notable Customers:

- Belmont County Fairgrounds
- Byrne Hollow Farms
- Coney Island WWTP
- CTI Beanmaker
- Dean Foods
- Imperial Landfill
- LOVECO
- Town of Strasburg
- Wahoo Creek Influent PS

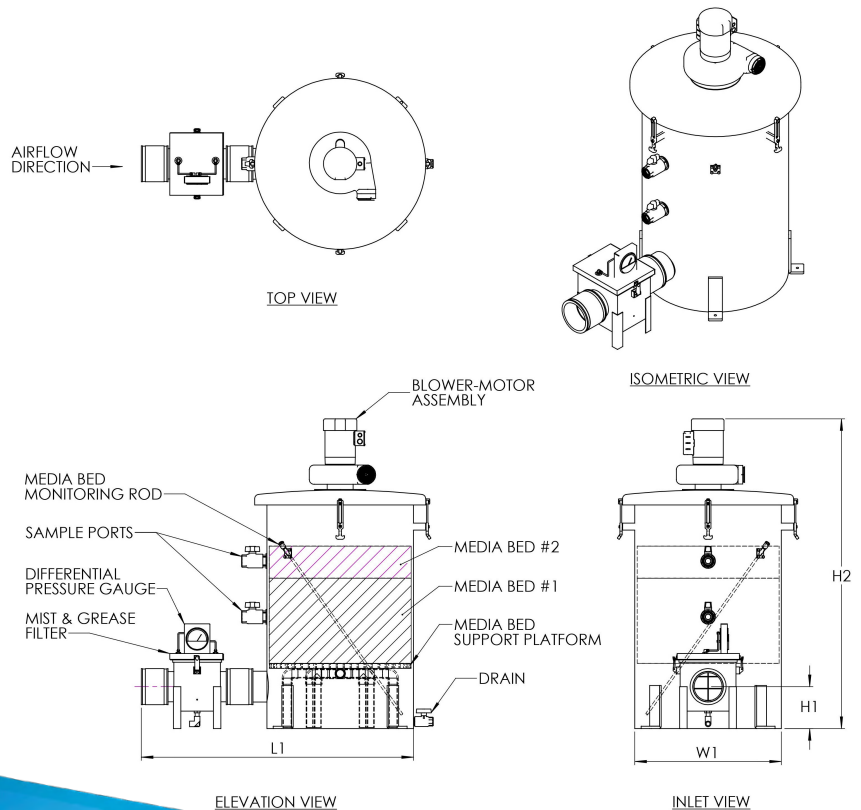

+1 678.935.1431

Toll Free: 866.543.7479

www.PureAirFiltration.com

6050 Peachtree Pkwy, Suite 240-187, Atlanta, GA, 30092 USA

# Vertical Bed Scrubber (VBS)



## Reliable, vertical air scrubber with high capacity

### SPECIFICATIONS:

Applications	Protecting Electronics, Wastewater Odor Control, Environmental Emission Control
Airflow Range	270 CMH (160 CFM) – 28,883 CMH (17,000 CFM) Municipal 271.8 CMH (160 CFM) - 11,310 CMH (22,620 CFM) Industrial <i>*Review the model selection table for more information.</i>
Configuration	Vertical airflow
Construction Material	<b>Municipal Standard:</b> Fiberglass reinforced plastic
Particulate Filtration	<b>Odor Control Applications:</b> Mist and Grease Filter <i>*Additional filter sizes and options available.</i>
Blower Configuration	<b>BLOWTHRU:</b> Standard for customers who want less noise from the blower <b>DRAWTHRU:</b> Optional and allows the blower to work in clean air, making it last longer and require lower maintenance <i>*Redundant blowers and other special options available.</i>
Customizable	Multiple sizes and configurations available, reference model selection chart for details. Add-on accessories like sound enclosures are available.



### BENEFITS:

- Low Maintenance: bulk loading and unloading options available
- Multiple beds available for adsorbent media
- Larger VBS models can have 2 beds with multiple banks in each bed
- Can be used with multiple types of media for different applications
- Low bypass and high efficiency
- Traditional, reliable, and simple solution with a larger airflow capacity than a drum scrubber

#### Media Bed Indicator:

This unit is equipped with a metal Media Bed Indicator to detect the remaining life of the media. See back for more details.

## MODEL SELECTION TABLE

VBS MODEL # VBS-	AIR FLOW RANGE CMH (CFM)	MOTOR MAX kW (HP)	MEDIA VOLUME M <sup>3</sup> (FT <sup>3</sup> )	SHIPPING WEIGHT KG (LBS)	OPERATING WEIGHT KG (LBS)
02	270-410 (160-240)	0.4 (0.5)	0.3 (9.4)	231 (510)	374 (825)
03	590-900 (350-530)	0.7 (1.0)	0.6 (21.2)	315 (695)	637 (1,405)
04	1,070-1,600 (630-940)	1.5 (2.0)	1.1 (37.7)	476 (1,050)	1,048 (2,310)
05	1,670-2,500 (980-1,470)	2.2 (3.0)	1.7 (58.9)	680 (1,500)	1,574 (3,470)
06	2,400-3,600 (1,410-2,120)	3.7 (5.0)	2.4 (84.8)	907 (2,000)	2,191 (4,830)
7.5	3,600-5,600 (2,120-3,310)	5.5 (7.5)	3.8 (132.5)	2,132 (4,700)	4,137 (9,120)
08	4,260-6,400 (2,510-3,770)	7.4 (10.0)	4.3 (150.8)	2,449 (5,400)	4,731 (10,430)
*08-DB	8,540-12,810 (5,030-7,540)	14.7 (20.0)	8.5 (301.6)	5,216 (11,500)	9,779 (21,560)
10	6,680-10,010 (3,930-5,890)	11.0 (15.0)	6.7 (235.6)	4,128 (9,100)	7,693 (16,960)
*10-DB	13,340-20,010 (7,850-11,780)	18.4 (25.0)	13.3 (471.2)	7,620 (16,800)	14,746 (32,510)
12	9,600-14,400 (5,650-8,480)	14.7 (20.0)	9.6 (339.0)	9,117 (20,100)	14,247 (31,410)
*12-DB	1,920-28,820 (11,310-16,960)	294.0 (40.0)	19.2 (678.5)	11,068 (24,400)	21,328 (47,020)

\*DB indicates larger models with dual beds. Each bed can have multiple banks of media.

### MEDIA BED INDICATOR:



This unit is equipped with a metal Media Bed Indicator. The indicator is positioned inside the system at an angle against the direction of airflow and detects the expiration level of the media.

- Dark, corroded coloration on indicator shows where media has expired. Once half the indicator has been corroded, contact the factory to replace the media and ensure the proper functioning of the system.
- Interested in instant notification of media life? Ask about the Electronic Media Bed Monitor that can be added to systems as an upgrade.

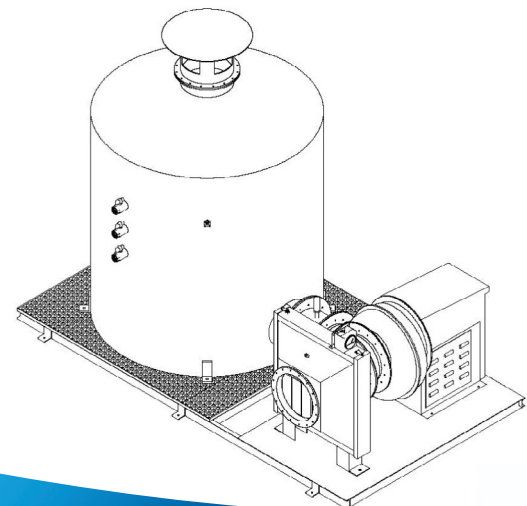
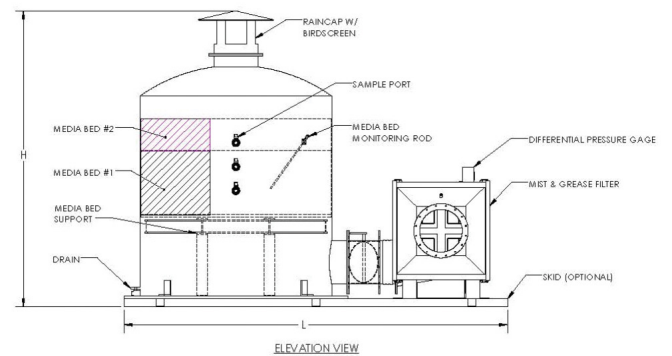
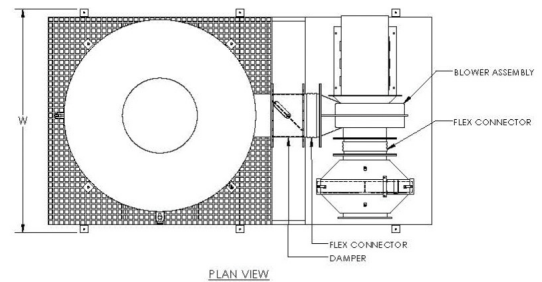

+1 678.935.1431

Toll Free: 866.543.7479

www.PureAirFiltration.com

6050 Peachtree Pkwy, Suite 240-187, Atlanta, GA, 30092 USA